

Kitchen Appliances

Distributed by:
CLEAN AIR SERVICES PTY. LTD.
1/147 GREENS ROAD DANDENONG SOUTH VICTORIA 3175
TEL: 03.97948182 FAX: 03.97935707
EMAIL: info@cleanairservices.com.au

LEV-RH60SA 60cm Slide-Out Range Hood



60cm Slide-Out Range Hood

LEV-RH60SA
For build-in applications
Stainless Steel finish
Slimline design
330m³ per hour suction capacity
Aluminium cassette filter
2 speed fan
2 x 15W globes for illumination

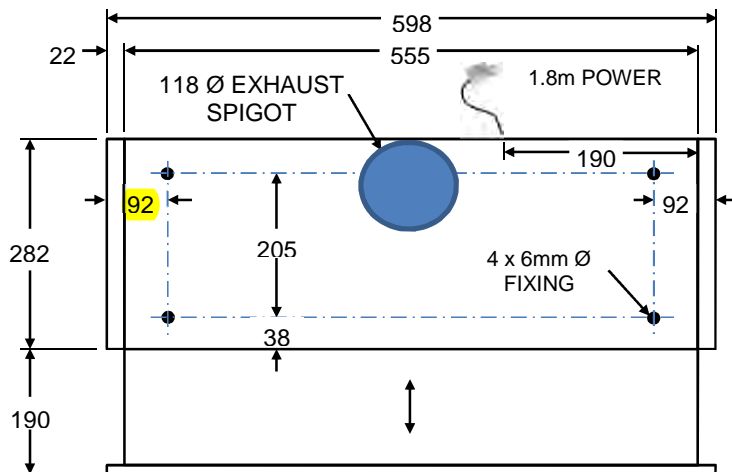
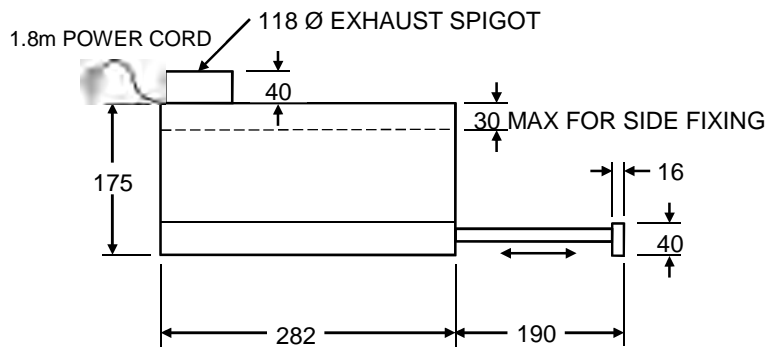



LEVANTE

LEV-RH90 Glass Canopy Range Hood



90cm Canopy Range Hood

LEV-RH90CA

Stainless steel finish with glass canopy

Soft touch controls

3 speed fan

Delayed fan-off function

Clock

Easy to install

Supplied fully assembled

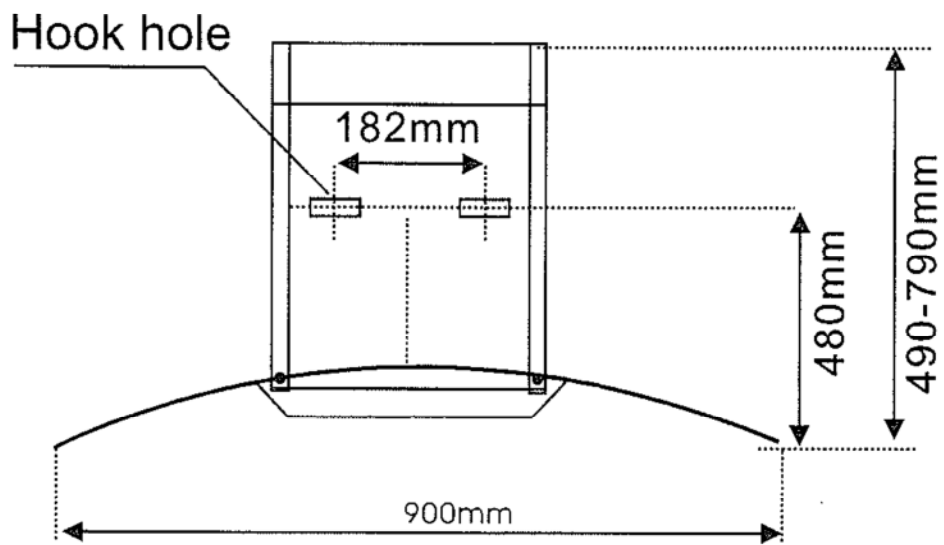



LEVANTE

LEV-CT60GWA 60cm Gas Cooktop



60cm Gas Cooktop

LEV-CT60WA

- 60cm inox gas cooktop
- Electronic Auto-Ignition
- Flame failure
- Cast iron trivets
- 1 x 1.0 kW Auxiliary Burner
- 2 x 1.75 kW Semi Rapid Burners
- 1 x 3.0 kW Rapid Burner

Bench top Cutout:

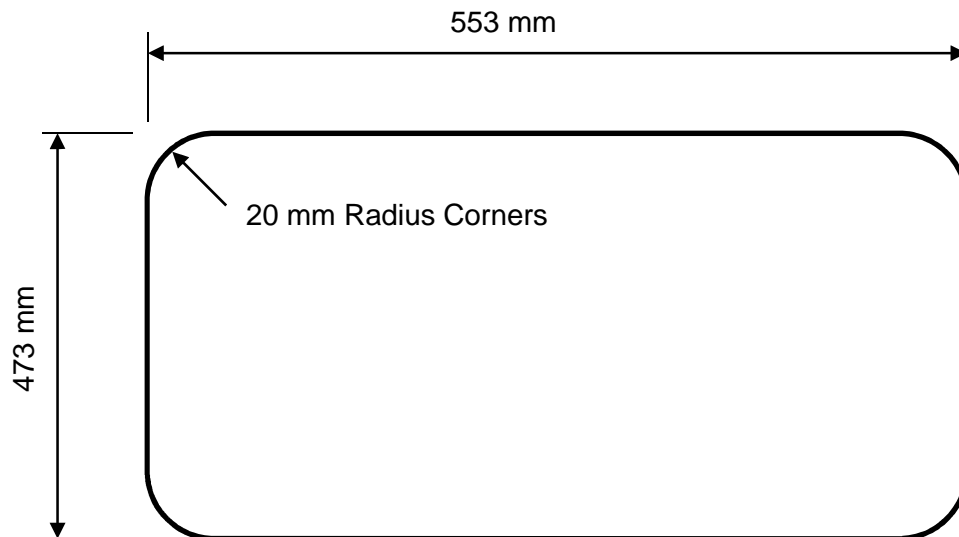

NOTE: Min. 20 mm clearance required under bottom of cooktop



LEVANTE

LEV-CT60ECA 60cm Electric Ceramic Cooktop



60cm Electric Cooktop - Ceramic

LEV-CT60ECA
60cm ceramic electric cooktop
Soft-Touch controls
Framelsee design for easy cleaning
2 x 1200W elements
2 x 1800W elements
9 power levels
Residual Heat warning lights

Bench top Cutout:

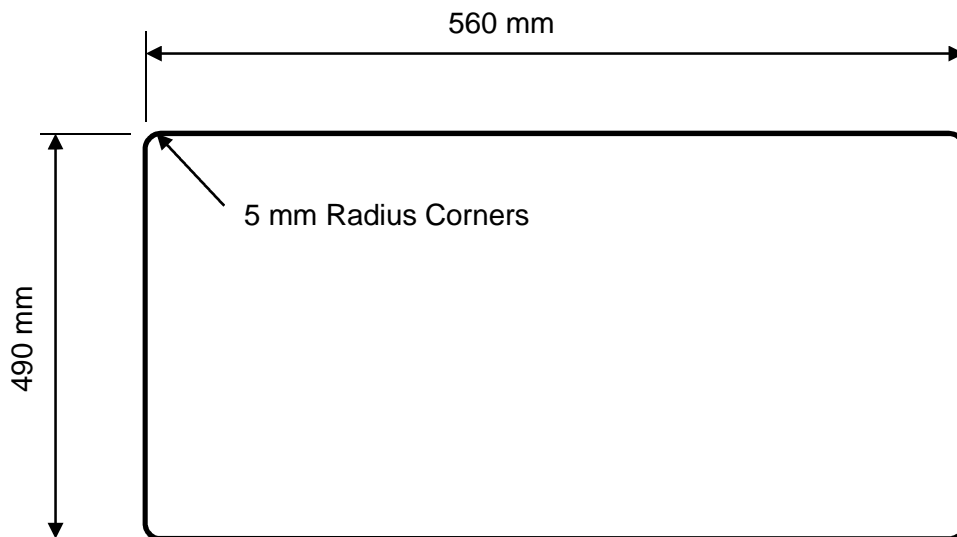

NOTE: Min. 200 mm clearance required under bottom of cooktop



LEVANTE

LEV-CT60ESA 60cm Electric Stainless Steel Cooktop



60cm Electric Cooktop - S/Steel

LEV-CT60ESA

60cm stainless steel electric cooktop

Solid Elements

2 x 1000W Elements

1 x 1500W Element

1 x 2000W Element

Bench top Cutout:

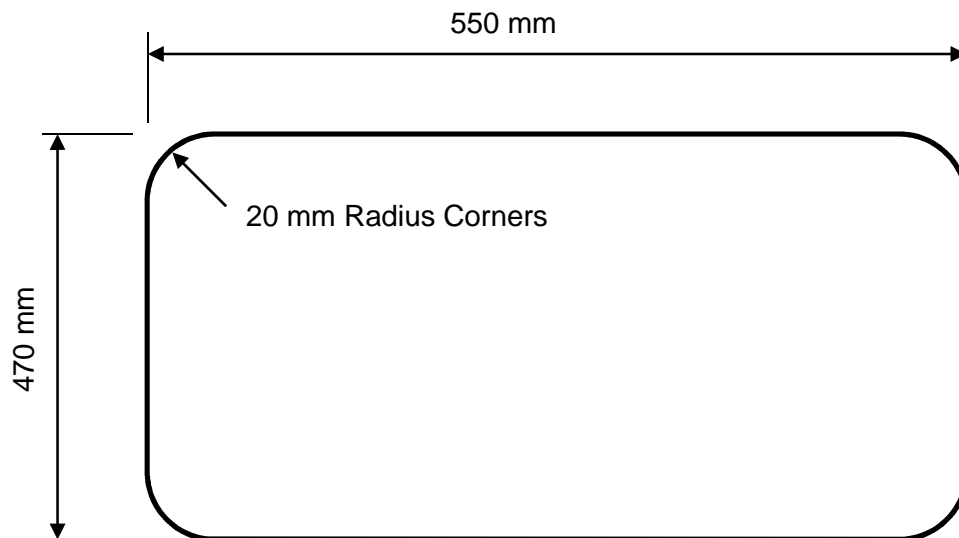

NOTE: Min. 200 mm clearance required under bottom of cooktop



LEVANTE

LEV-WO60FA 60 cm Electric Wall Oven



60cm Electric Wall Oven

LEV-WO605FA

5 cooking functions

Mechanical 120 minute minder with auto off

56 litre net capacity

Fan forced

Cavity cooling system

Mechanical thermostat

Cooler to touch double glazed oven door

Removable glass door for easy cleaning

Accessories include baking tray and shelves

Bench front Cutout:

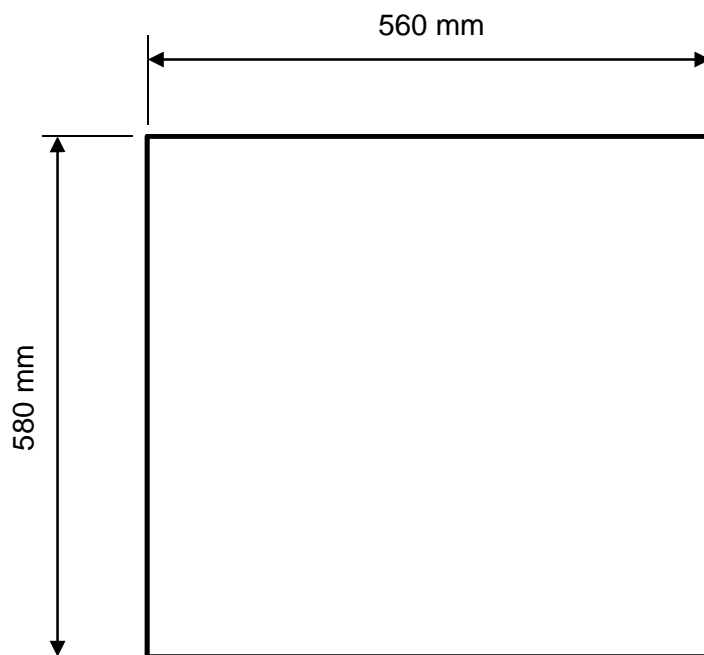

NOTE: Allow ventilation under oven



LEVANTE

LEV-DW605A 60 cm Stainless Steel Dishwasher



60cm Freestanding Dishwasher

LEV-DW605A
12 place settings
Stainless Steel front panel
Easy to use electronic controls
5 washing programs
Height adjustable upper basket
Dimensions: 600 x 580 x 850 mm
Water consumption 16L

Bench front Cutout:

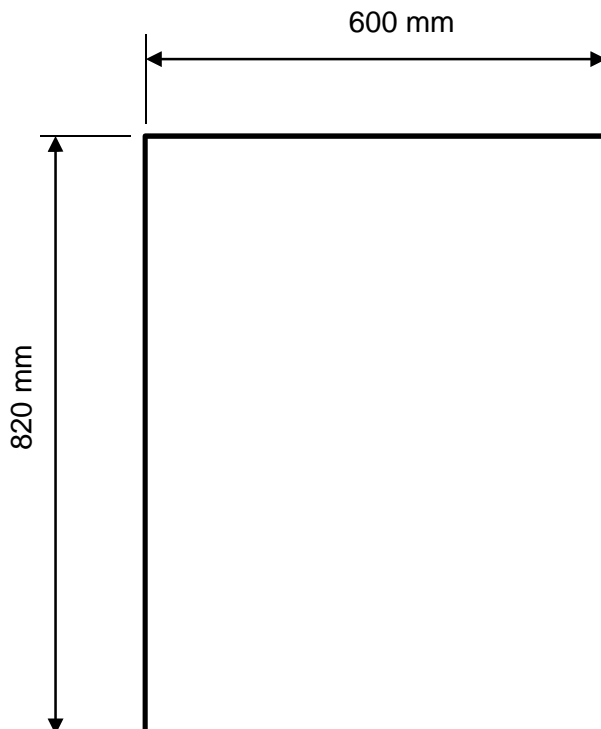



LEVANTE

LEV-KS0134 1 + 1 ¾ Stainless Steel Kitchen sink



Kitchen Sink
LEV-KS0134 L/R

Bench top Cutout:

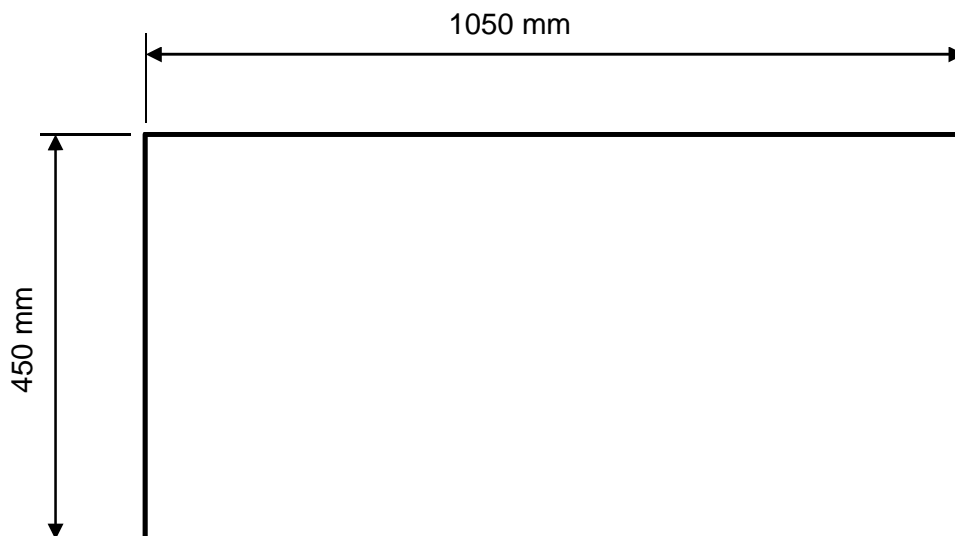

Distributed by:

CLEAN AIR SERVICES PTY. LTD.

1/147 GREENS ROAD DANDENONG SOUTH VICTORIA 3175

TEL: 03.97948182 FAX: 03.97935707

EMAIL: info@cleanairservices.com.au